

DIGGER 50

The small hydraulic excavator and power unit

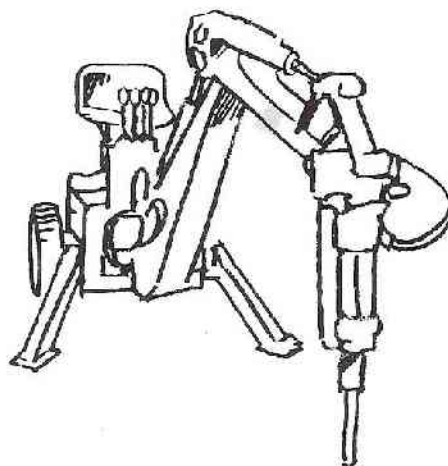

A Swedish design for Swedish conditions.
DIGGER 50 can be driven by a petrol, LPG or diesel engine or by
an electric motor.

- **DIGGER 50** the small hydraulic excavator with a great potential.
- The digging capacity and versatility of the **DIGGER 50** are quite fantastic—especially when working in confined and low spaces.
- The front outriggers can be folded to reduce the overall width to 90 cm. Is even less space available, the wheels too can be easily detached, in which case the overall width is reduced to only 60 cm.
- The **DIGGER 50** can be easily moved from site to site by connecting a draw-bar to the machine.
- The **DIGGER 50** can be attached to motor cars with an ordinary traction coupling.
- The **DIGGER 50** can be easily driven on to and from a trailer.
- The hydraulic system of a **DIGGER 50** is suitable for most hydraulic tools such as power hammers, drilling machines, grinders, water pumps, generators, electric welders, cutting tools etc.
- The **DIGGER 50** is therefore also a hydraulic power unit.
- The **DIGGER 50** has been designed in Sweden for Swedish conditions. All moving parts are provided with bushes of high-grade Swedish steel, and the slewing head is fitted with spherical plain bearings for maximum life.

Technical data

Digging depth	2.6 m
Digging height	2.5 m
Discharge height	1.5 m
Max. reach	3.1 m
Dipper arm force	1200 kg
Carrying capacity, fully extended	100 kg
Bucket cylinder pressure	5000 kg
Slewing angle	180°
Max. width with outriggers	2.7 m
Min. width with wheels	0.9 m
Min. width without wheels	0.6 m
Weight	500 kg

Drive options

Petrol engine, LPG IM 350,
Honda 10 hp
Diesel engine, Lombardini 7.5 hp
Electronic motor 380/220 V

Hydraulic system

2- or 4-lever operation
Pump, 28 litres/min. 3600 rev/min
Working pressure 150 bars
5 spool valves with overflow operating
6 hydraulic cylinders.
Volume of hydraulic system with tank
34 litres
Volume of hydraulic tank 25 litres.

Bucket

Standard bucket 38 cm

Optional equipment

Grading bucket 60 cm
Cable trenching scoop 25 cm
Trenching bucket
Grab
Excavating bucket
Rubber support plates
Adjustable outriggers
Draw-bar
Trailer
Dolly
Cable winch
Motor car unit
Pierce auger
Hydraulic winder

Also other hydraulic tools can be attached to the **DIGGER 50**.

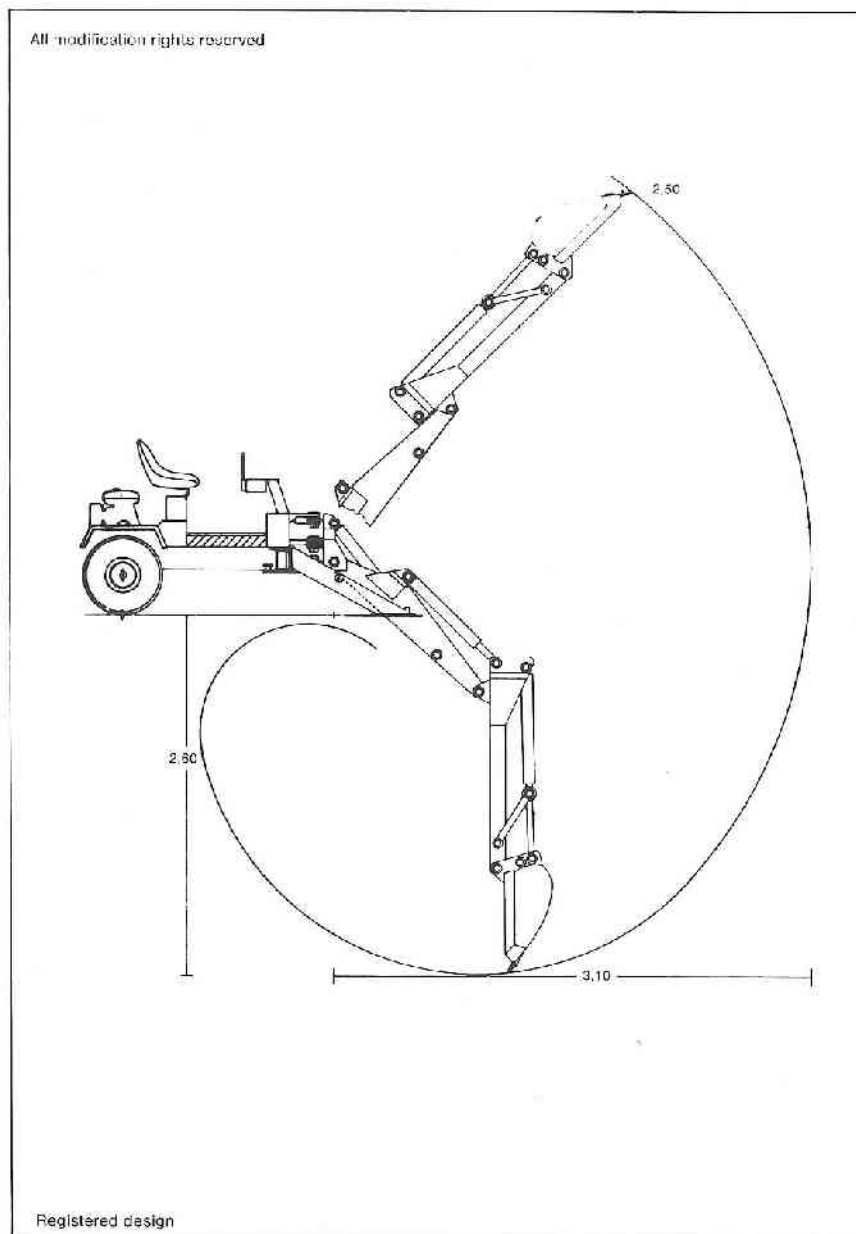

This machine can also be built according to your specifications. Smaller models—**DIGGER 35** and **25**—are also available.

New: Power unit available as optional equipment—a hydraulic motor to be attached to the bucket mounting.

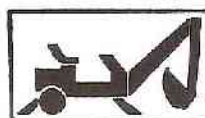

DIGGER
SVENSKA AB

DIGGER SVENSKA AB · Norra Kolonnvägen 18 · Box 421 · 191 04 SOLLENTUNA · SWEDEN

Phone +46 896 0150

For DIGGER sales and information